

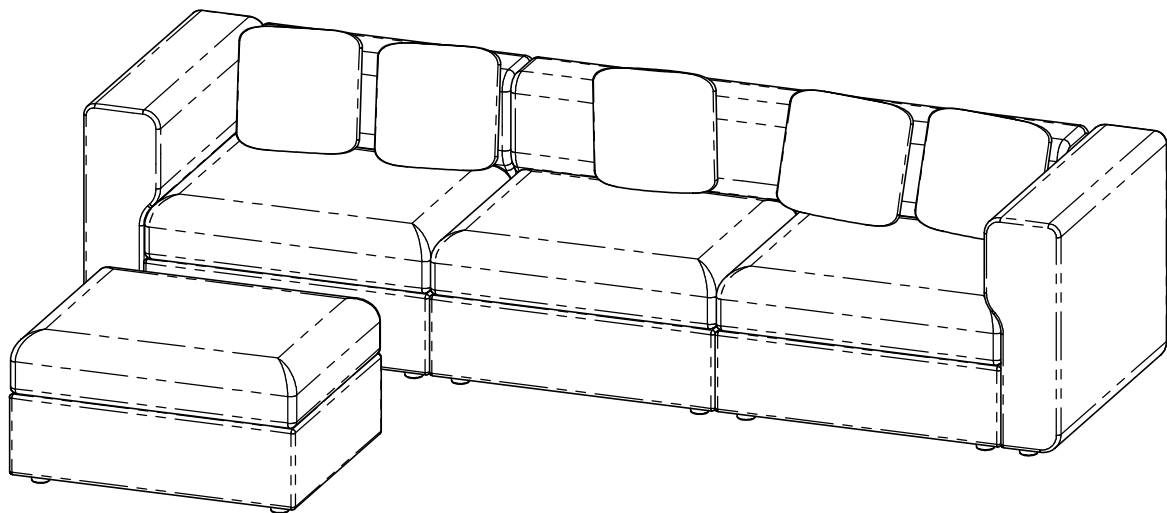

Combination Sofa



CUSTOMER FIRST INTEGRITY

QEZEOMService@outlook.com

GuideTo Assembly Model:L2158

Thank you for purchasing this product. Please read these instructions fully before starting assembly, then follow the simple step by step guide.

TOP TIPS BEFORE YOU START!

1. Please check that all parts & hardware are present before you start the assembly of your furniture. Do not destroy any of the packaging until you are certain that you have all the necessary parts for assembly.
2. For ease and speed of assembly, we recommend that before you commence each step of the assembly, please identify all the parts required for that step.
3. We recommend that where possible, all items are assembled near to the area in which they will be placed in use, to avoid moving the product unnecessarily once assembled.
4. For the protection of your furniture, particularly items of high gloss finish, we recommend that the product is placed on a protected surface during assembly to prevent any damage.
5. During assembly please take care not to over-tighten any fittings, as this may damage the product.
6. Keep children and animals away from the work area, small parts could cause choking if swallowed.

Tools Required For Assembly



DO NOT USE POWER TOOLS TO ASSEMBLE THIS PRODUCT. USE OF POWER TOOLS WILL INVALIDATE ANY CLAIM AND MAY DAMAGE THIS PRODUCT MAKING IT UNSAFE.

Rubber Hammer



Self-provided general tool diagram:

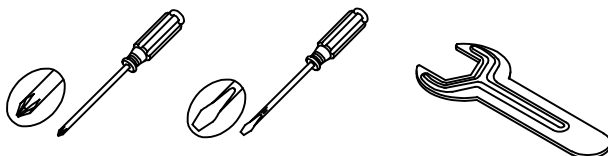

Tape Measure

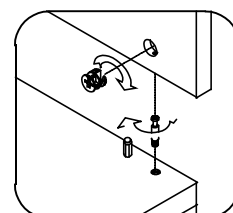
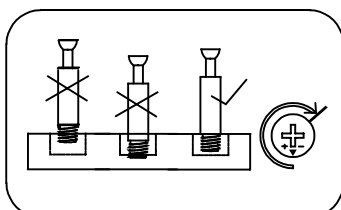

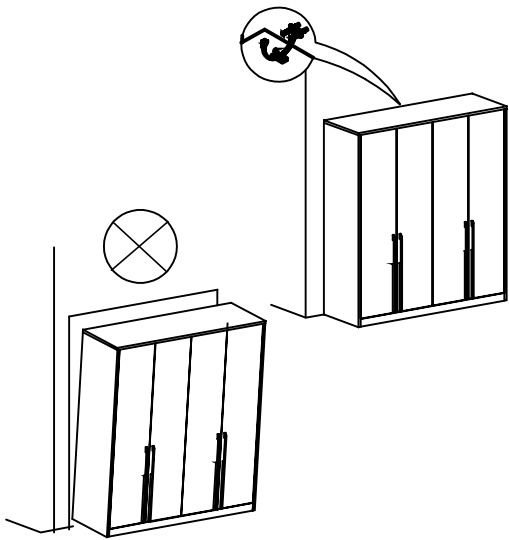

matters needing attention

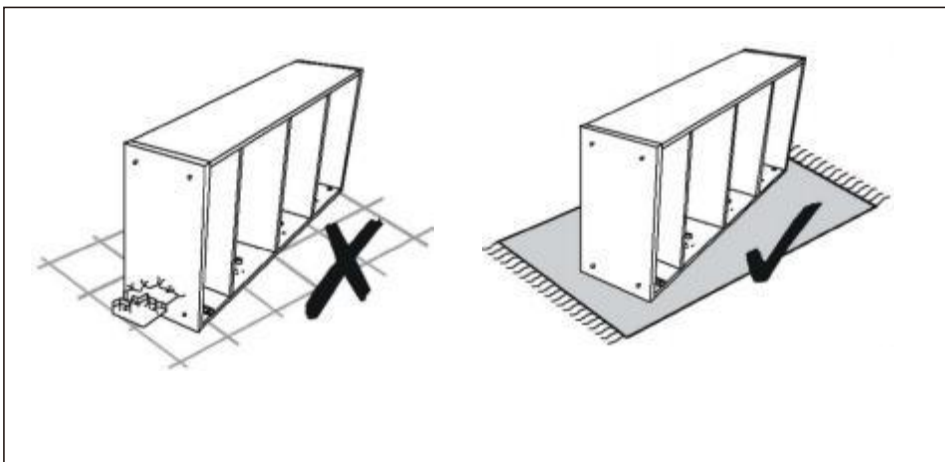
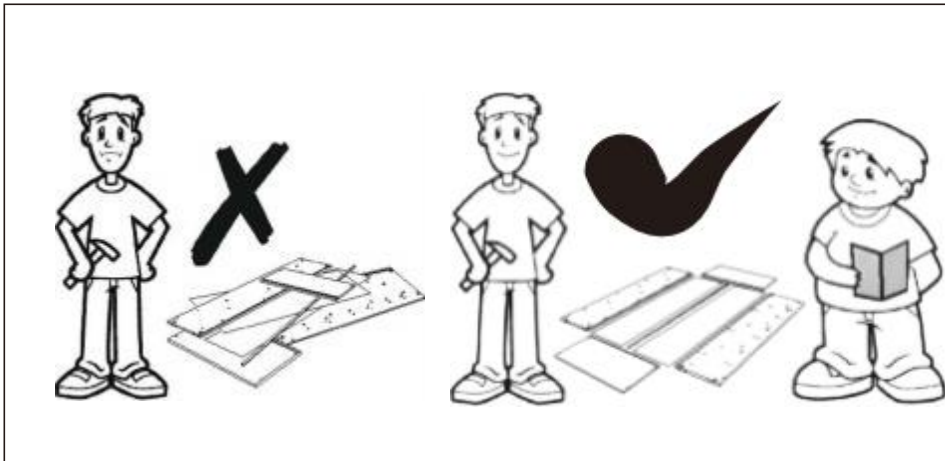

Bill of Material

No.	Material Name	Qty	No.	Material Name	Qty
B01	Left Armrest	1	B08	Right Seat Frame	1
B02	Left Backrest	1	B09	Right Cushion	1
B03	Left Seat Frame	1	B10	Right Backrest	1
B04	Left Cushion	1	B11	Right Armrest	1
B05	Middle Seat Frame	1	B12	Footrest	1
B06	Middle Cushion	1	B13	Throw Pillow A	3
B07	Middle Backrest	1	B14	Throw Pillow B	2

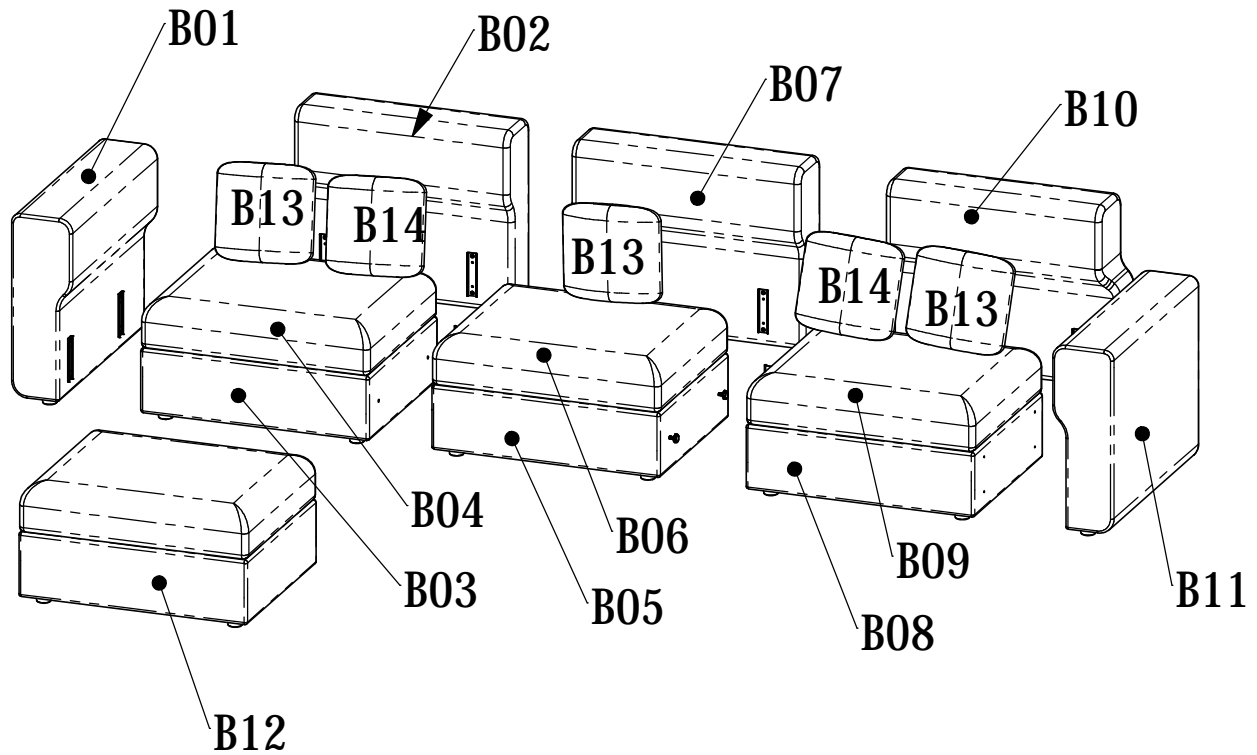

L2158 Hardwares for Assembly

L21581: Armrest

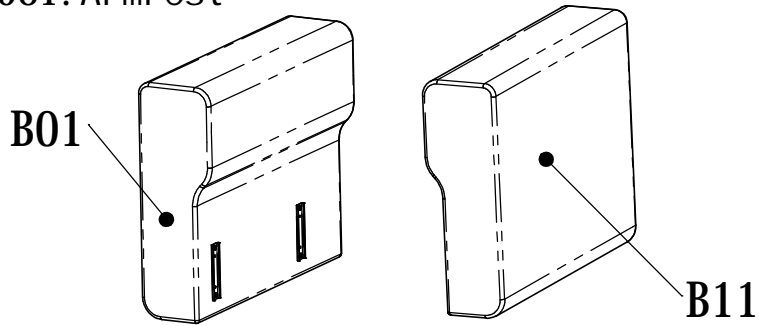

L21582: Left Seat

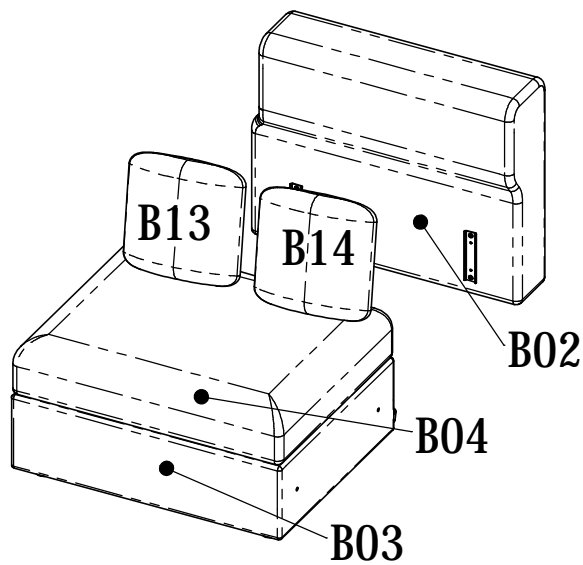

HA0093



Hexagon Nut
2PCS

H2529



Cylinder Leg
8PCS

HS0027



Detent Pin
4PCS

HZ0032



Gasket
8PCS

H1133



Flathead Screw
8PCS

HA0092



Hexagon Screw
2PCS

L21583: Right Seat

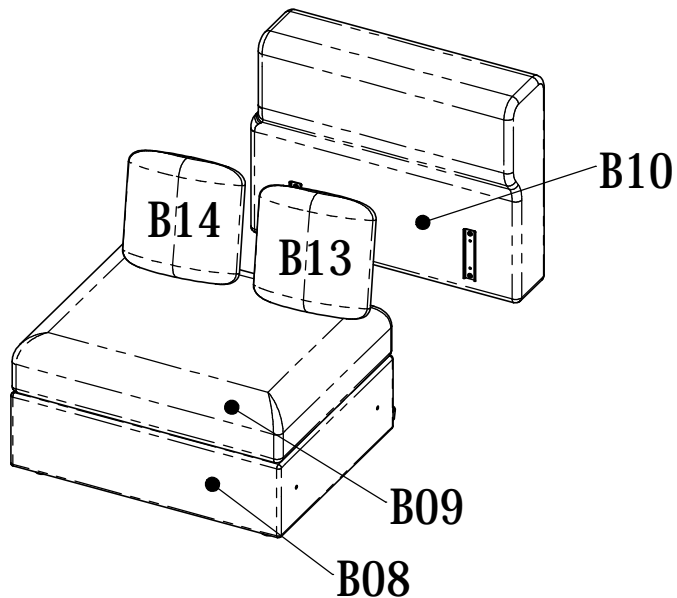

HA0093



Hexagon Nut
2PCS

H2529



Cylinder Leg
8PCS

HS0027



Detent Pin
4PCS

HZ0032



Gasket
8PCS

H1133



Flathead Screw
8PCS

HA0092



Hexagon Screw
2PCS

L2158 Hardwares for Assembly

L21584: Middle Seat

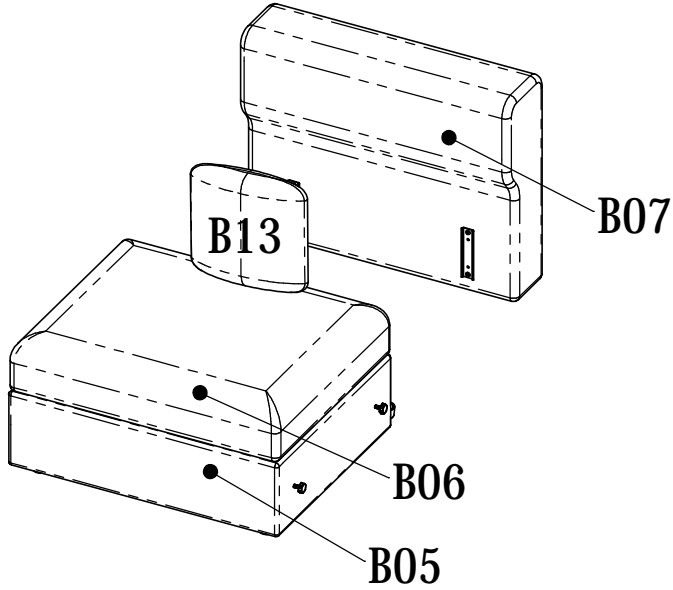

HA0093



Hexagon Nut

2PCS

H2529



Cylinder Leg

6PCS

HS0027



Detent Pin 2PCS

HZ0032



Gasket 6PCS

H1133



Flathead Screw
4PCS

HA0092



Hexagon Screw
2PCS

L21585: Footrest

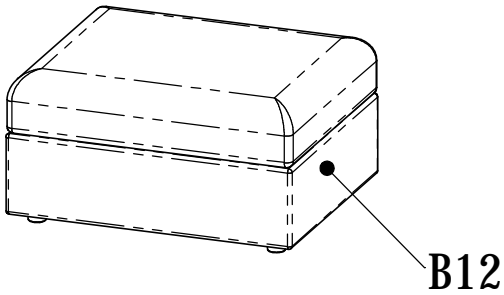

H2529



Cylinder Leg
4PCS

HZ0032



Gasket
4PCS

1. (Left and right seats) Take out the hardwares and locate the Cylinder Legs. Install them according to the diagram.

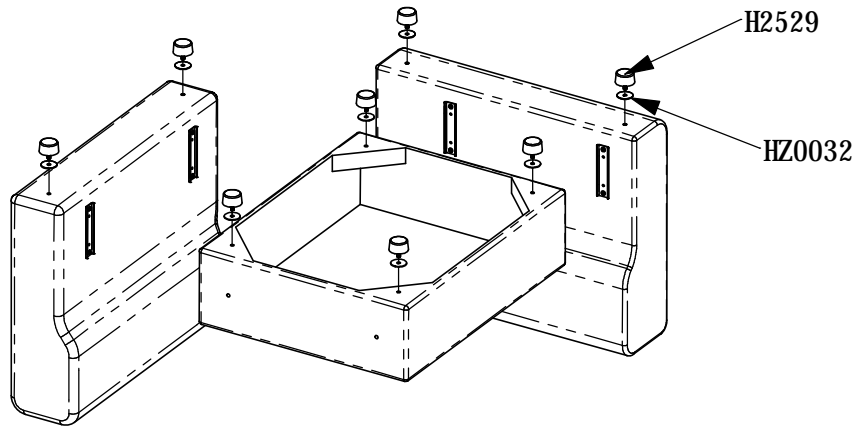

2. (Left and right seats) Assemble the hardwares to the seat frame according to the diagram.

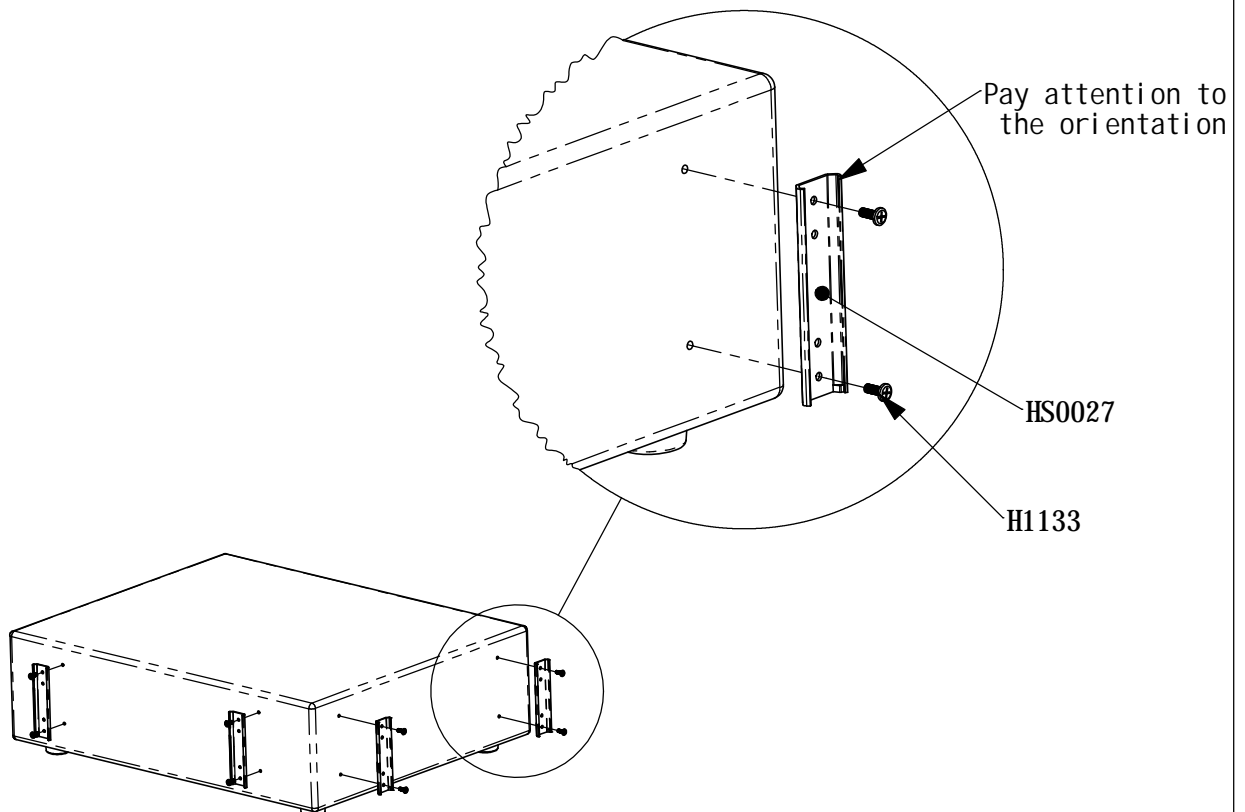

3. (Left and right seats) Take out the cushions and throw pillows from the seat frame and place them on the frame. Connect the armrest and backrest to the seat frame using hardware.

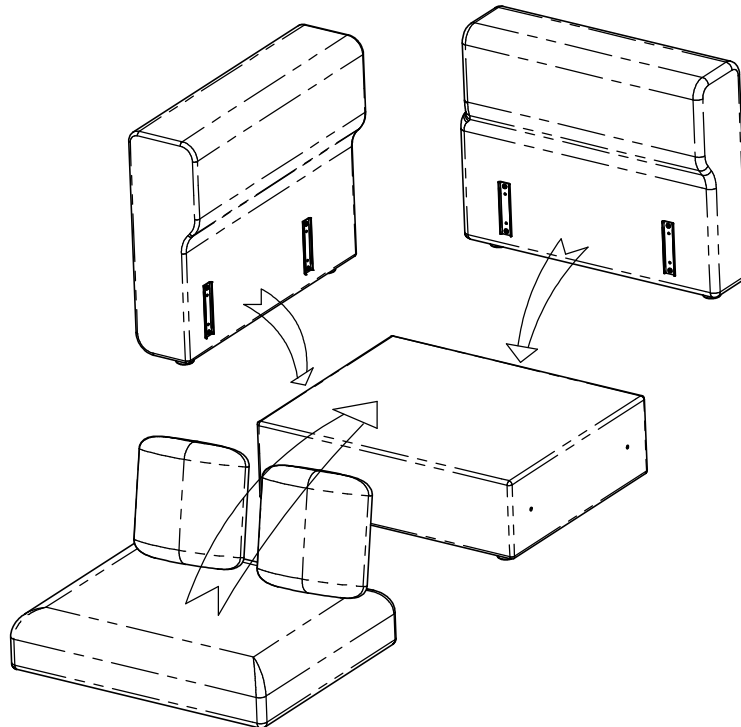

Note: The left and right seats are mirror-image structures.

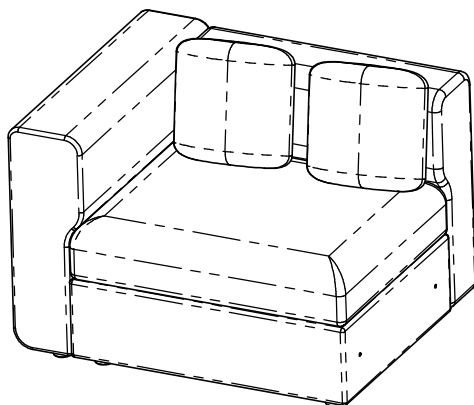

Left Seat

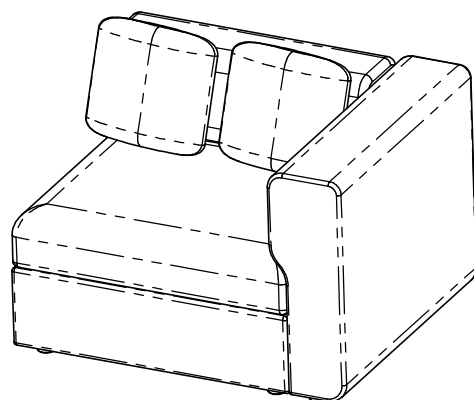

Right Seat

4. (Middle Seat) Take out the hardwares and locate the Cylinder Legs. Install them according to the diagram.

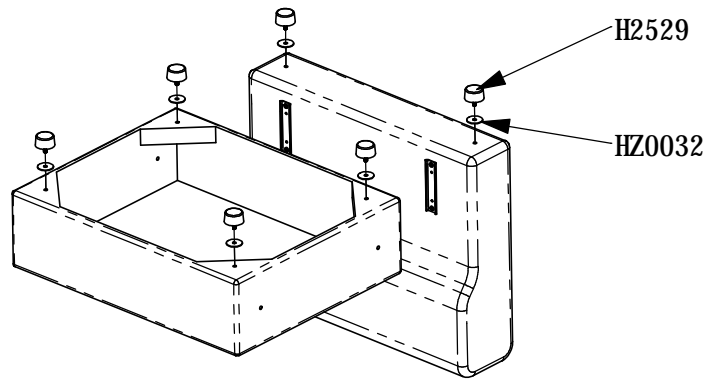

5. (Middle Seat) Assemble the hardwares to the seat frame according to the diagram.

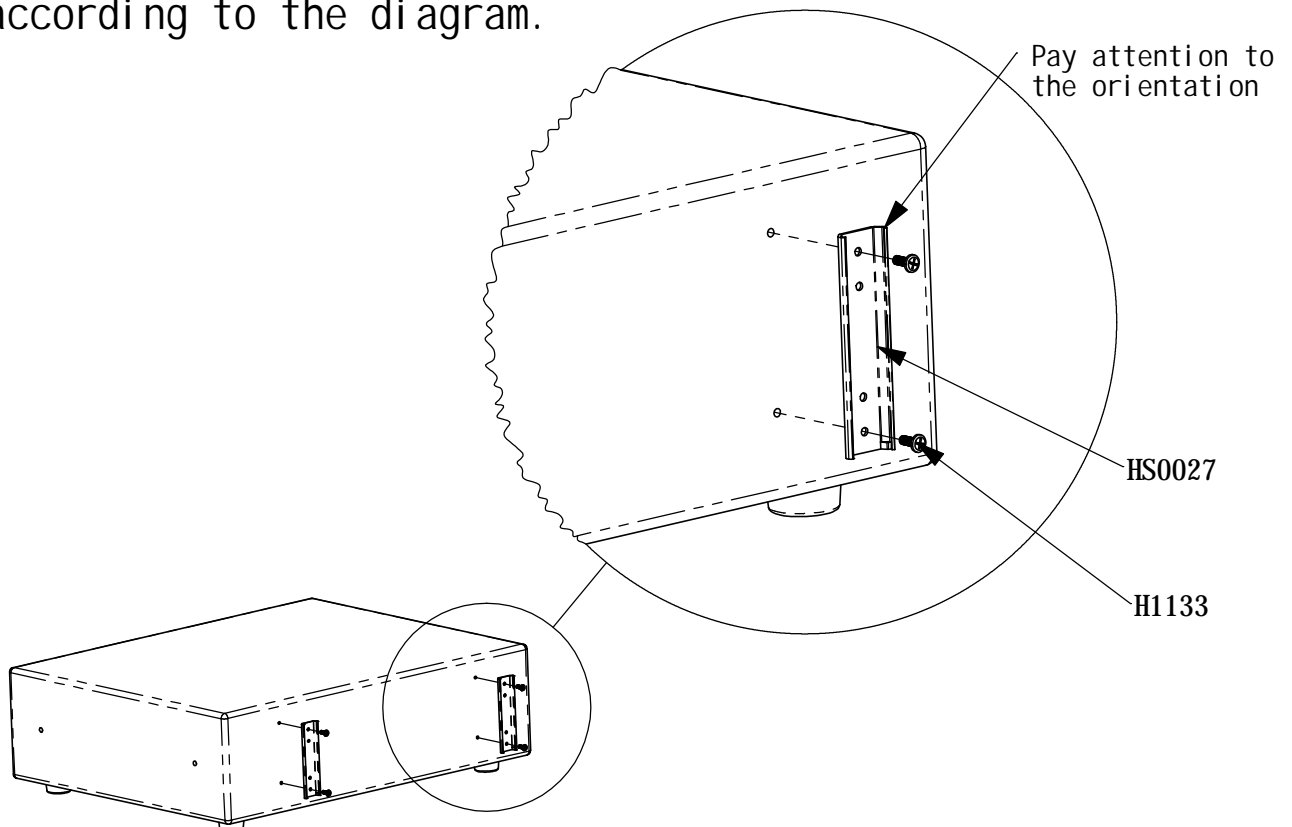

6. Take out the cushion and throw pillow and place them on the frame. Connect the backrest to the seat frame using hardware.

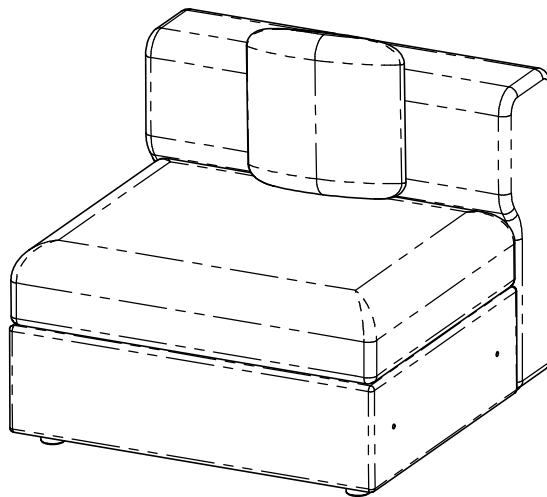
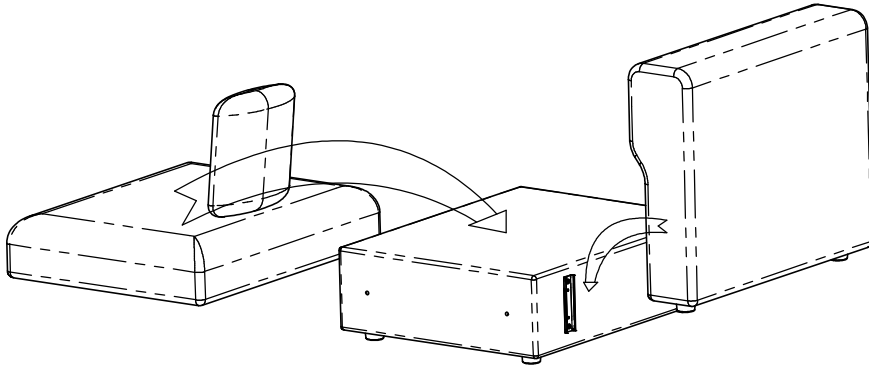

Middle Seat

7. (Footrest) Take out the hardware and locate the Cylinder Legs. Install them according to the diagram.

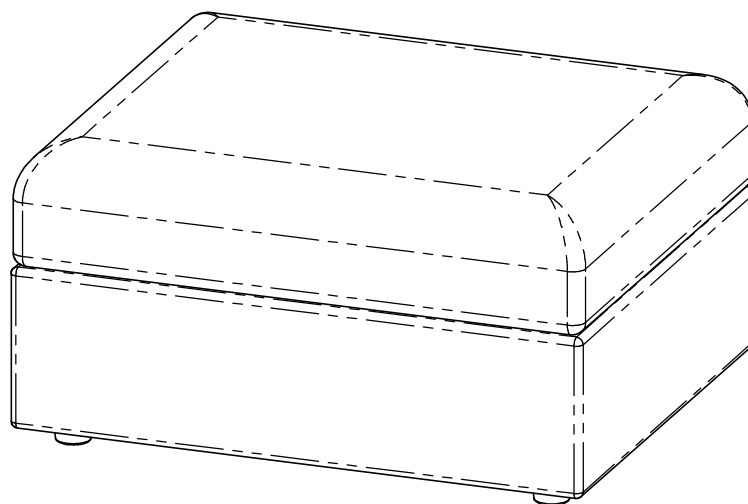
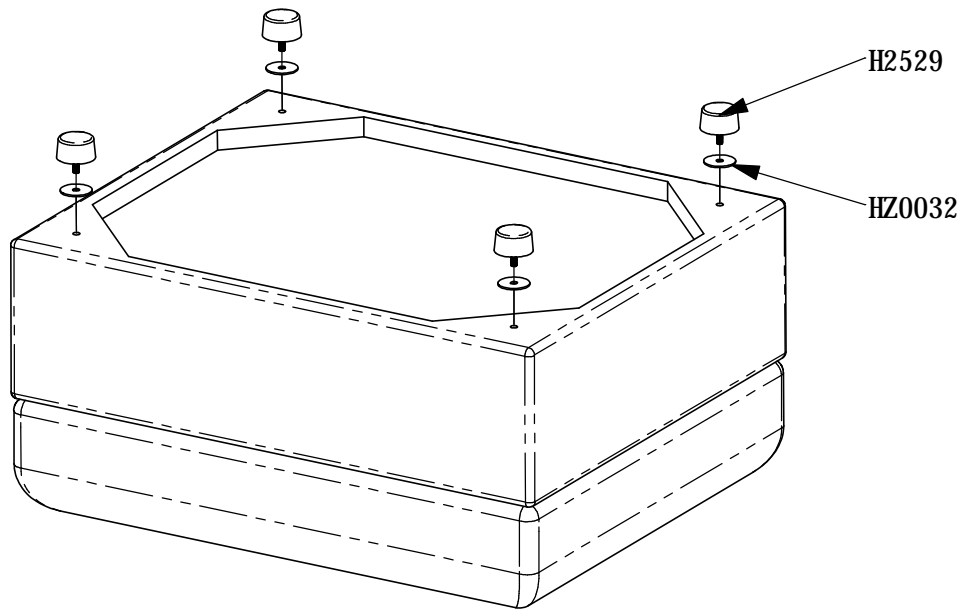

Footrest

8. Use the hardware to assemble and connect the sofa components into a cohesive unit.

