

# PRODUCT CARE HANDBOOK

a guide to protecting your product



I'm made from 100%  
recycled paper



866-504-7728



support@guyii.com

www.guyii.com

### Coated with matte finish

Synthesize with varnish as main and matte agent as auxiliary

### The board is coated with polymer emulsion

As a base coat polished for 6 times

### Polishing undercoat

Polish with waterproof sandpaper and abrasive cloth

### Medium density fiberboard

Not easy to deform or crack

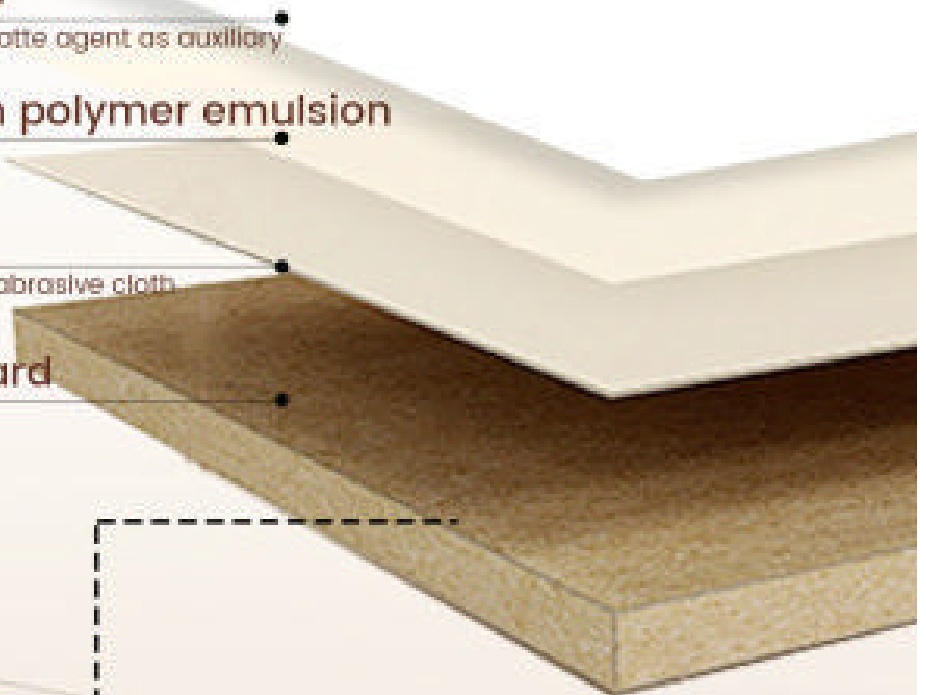
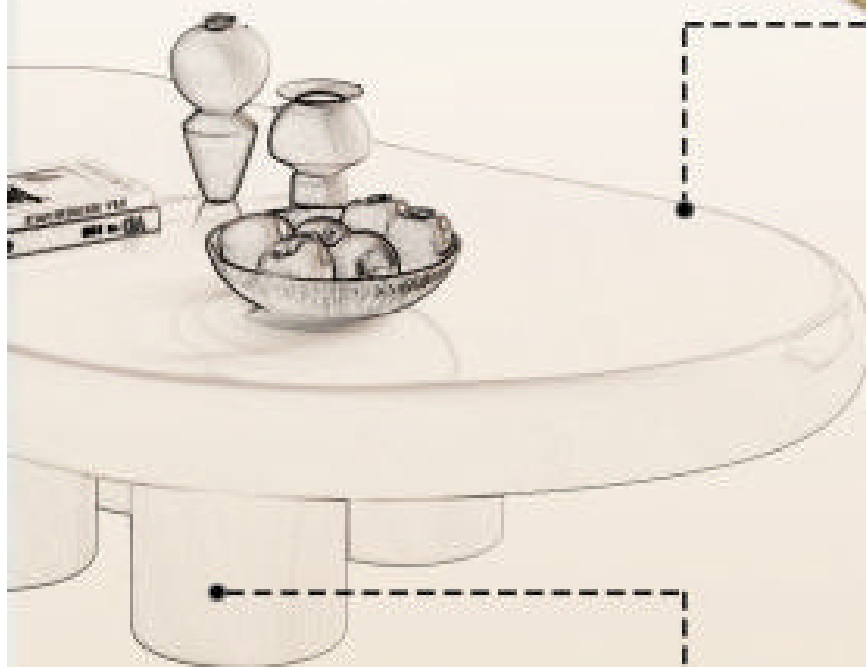

### Coated with matte finish

Synthesize with varnish as main and matte agent as auxiliary

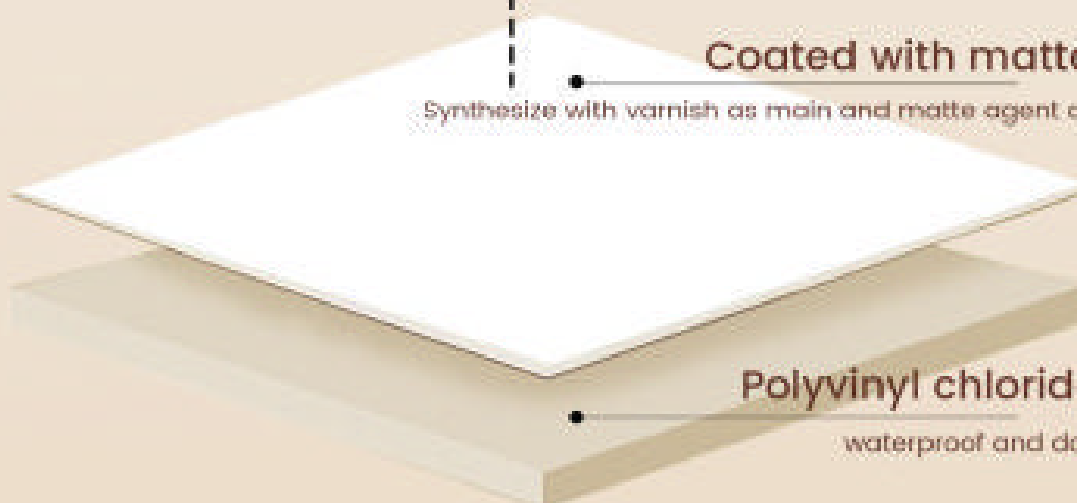

### Polyvinyl chloride base

waterproof and damp-proof

Thank you for purchasing this product. Please read these instructions fully before starting assembly, then follow the simple step by step guide.

## TOP TIPS BEFORE YOU START!

1. Please check that all parts & hardware are present before you start the assembly of your furniture. Do not destroy any of the packaging until you are certain that you have all the necessary parts for assembly.
2. For ease and speed of assembly, we recommend that before you commence each step of the assembly, please identify all the parts required for that step.
3. We recommend that where possible, all items are assembled near to the area in which they will be placed in use, to avoid moving the product unnecessarily once assembled.
4. For the protection of your furniture, particularly items of high gloss finish, we recommend that the product is placed on a protected surface during assembly to prevent any damage.
5. During assembly please take care not to over-tighten any fittings, as this may damage the product.
6. Keep children and animals away from the work area, small parts could cause choking if swallowed.

## Tools Required For Assembly



DO NOT USE POWER TOOLS TO ASSEMBLE THIS PRODUCT. USE OF POWER TOOLS WILL INVALIDATE ANY CLAIM AND MAY DAMAGE THIS PRODUCT MAKING IT UNSAFE.

Rubber Hammer

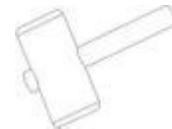

Self-provided general tool diagram:

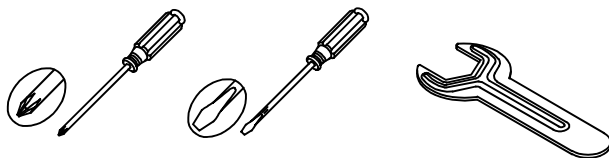

Tape Measure

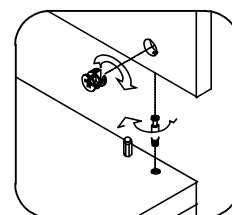
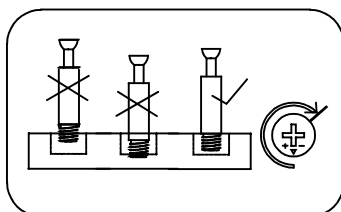

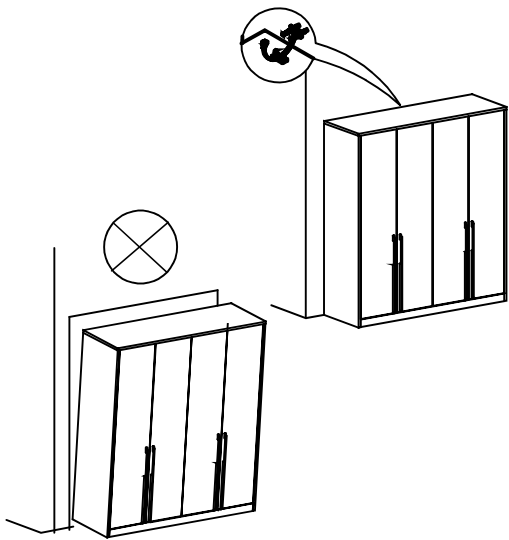



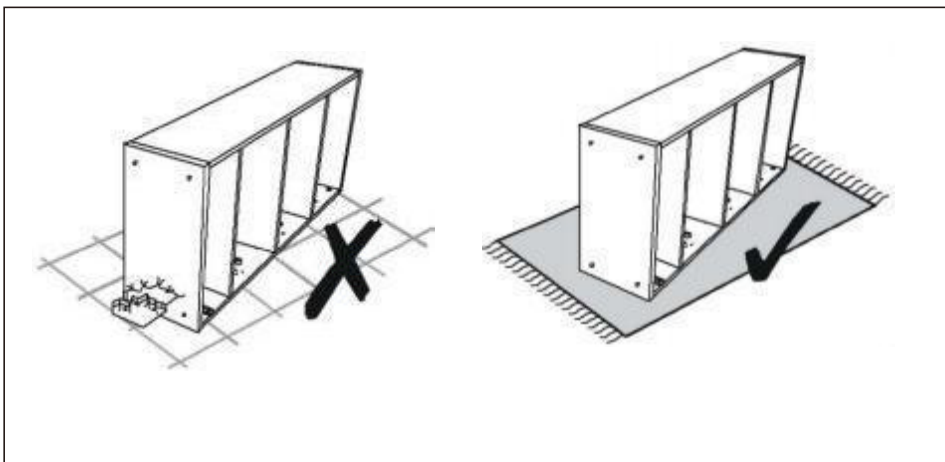
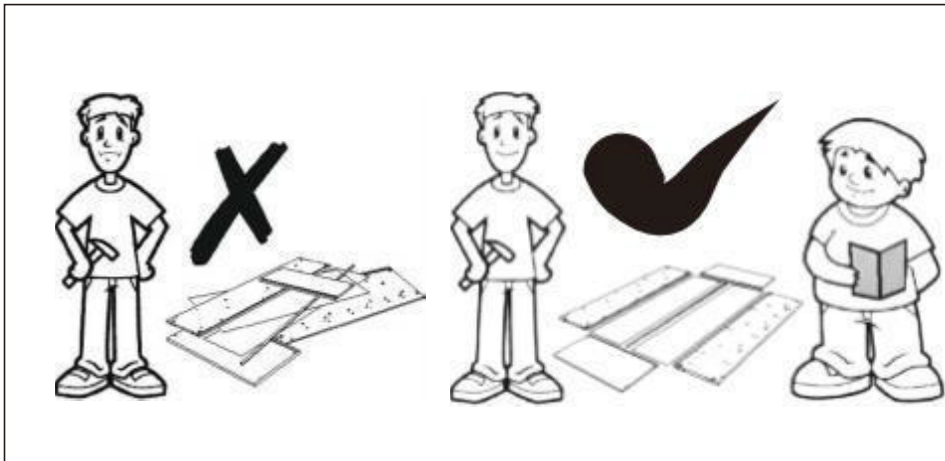

matters needing attention



# GY5281HW Installation Hardware List

H5106  L-shaped external hexagonal wrench 5# 1PCS	H1130  Flat headed hexagonal screw M8 * 35 22PCS	H1511  Shim M8 * 18 30PCS	H1712  Flat headed hexagonal screw M8 * 60 8PCS
---	--	--	---

## GY5281HW Installation steps

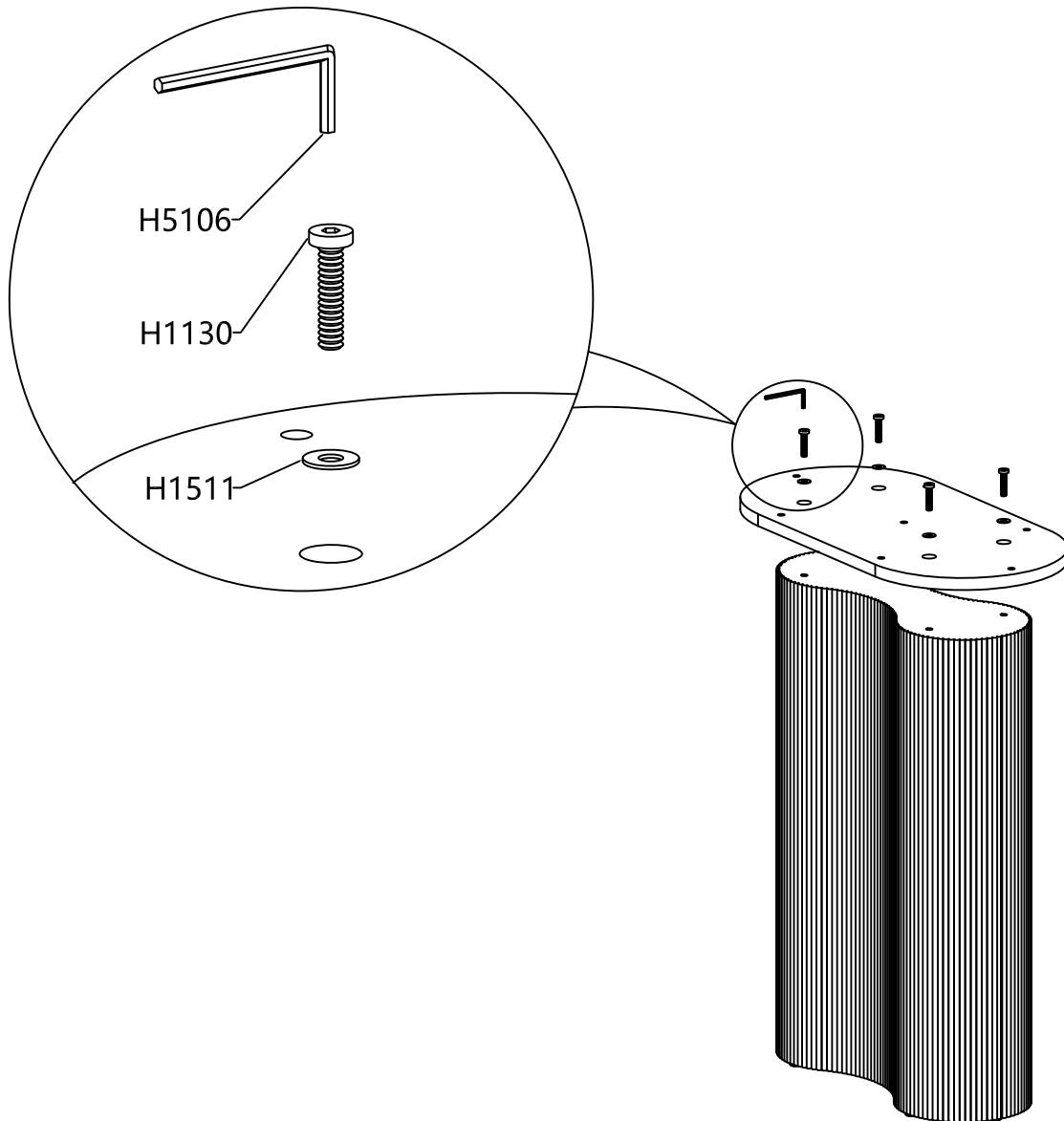

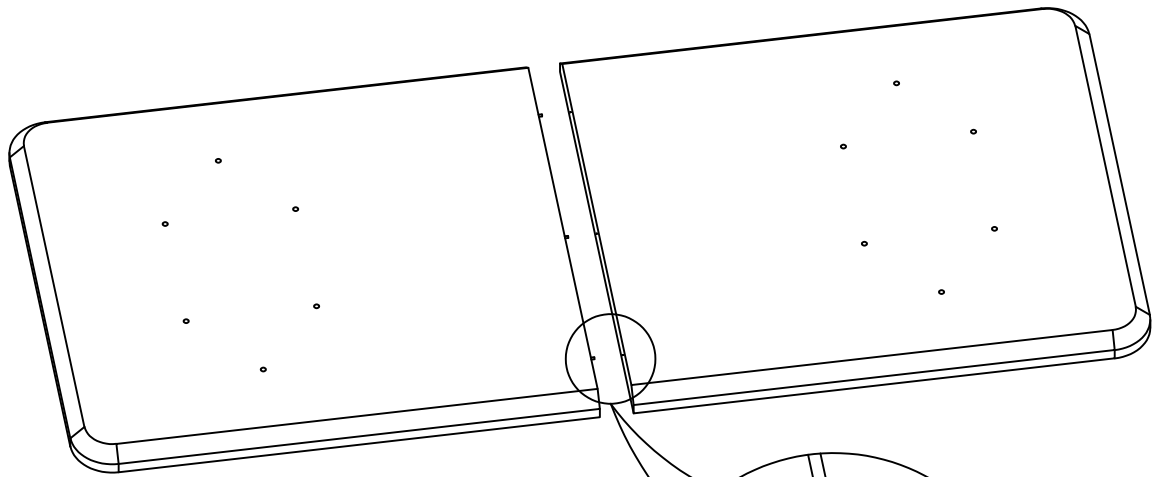



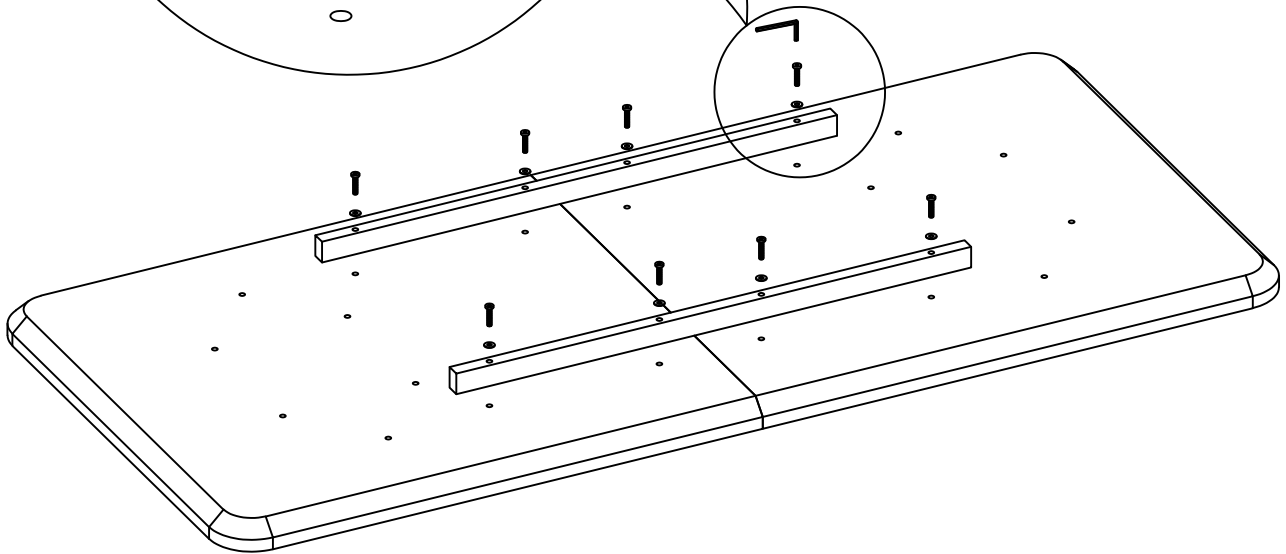
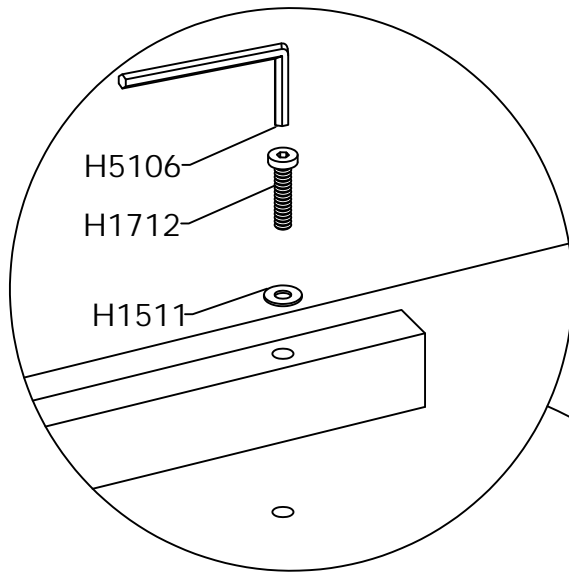
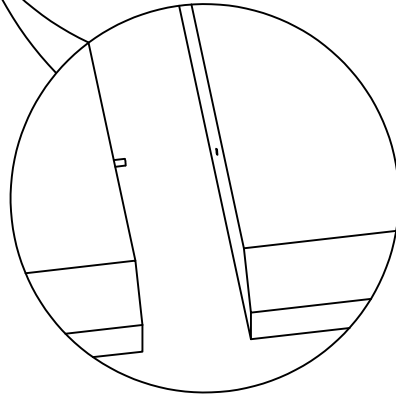

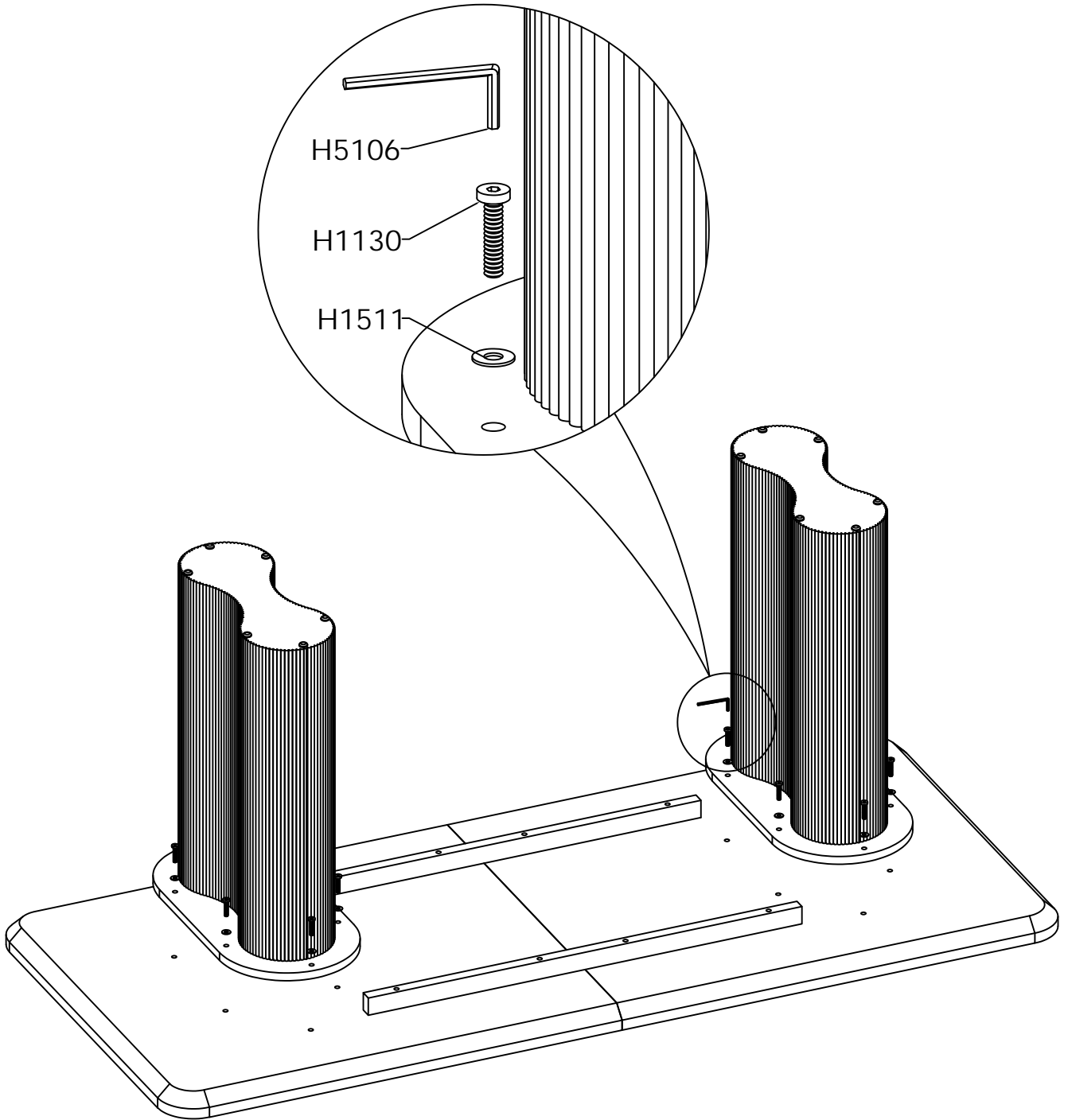

Insert after  
aligning the  
locating pins





## GY5281HW Maintenance Hardware List

<p>H5106</p>  <p>L-shaped external hexagonal wrench 5#</p> <p style="text-align: right;">1PCS</p>	<p>H1130</p>  <p>Flat headed hexagonal screw M8 * 35</p> <p style="text-align: right;">22PCS</p>	<p>H1511</p>  <p>Shim M8 * 18</p> <p style="text-align: right;">30PCS</p>	<p>H2502</p>  <p>White ground nail</p> <p style="text-align: right;">12PCS</p>
<p>H1319</p>  <p>Internal and external nut (with collar) M8 * 18</p> <p style="text-align: right;">30PCS</p>	<p>H1712</p>  <p>Flat headed hexagonal screw M8 * 60</p> <p style="text-align: right;">8PCS</p>	<p>HG1003</p>  <p>Positioning pin</p> <p style="text-align: right;">3PCS</p>	

## GY5281HW Repair Panel List

B01-1*1 Table top (convex)
B01-2*1 Table top (concave)
B02*2 Support tube
GY5322*1 Table legs
B03*1 Connection board

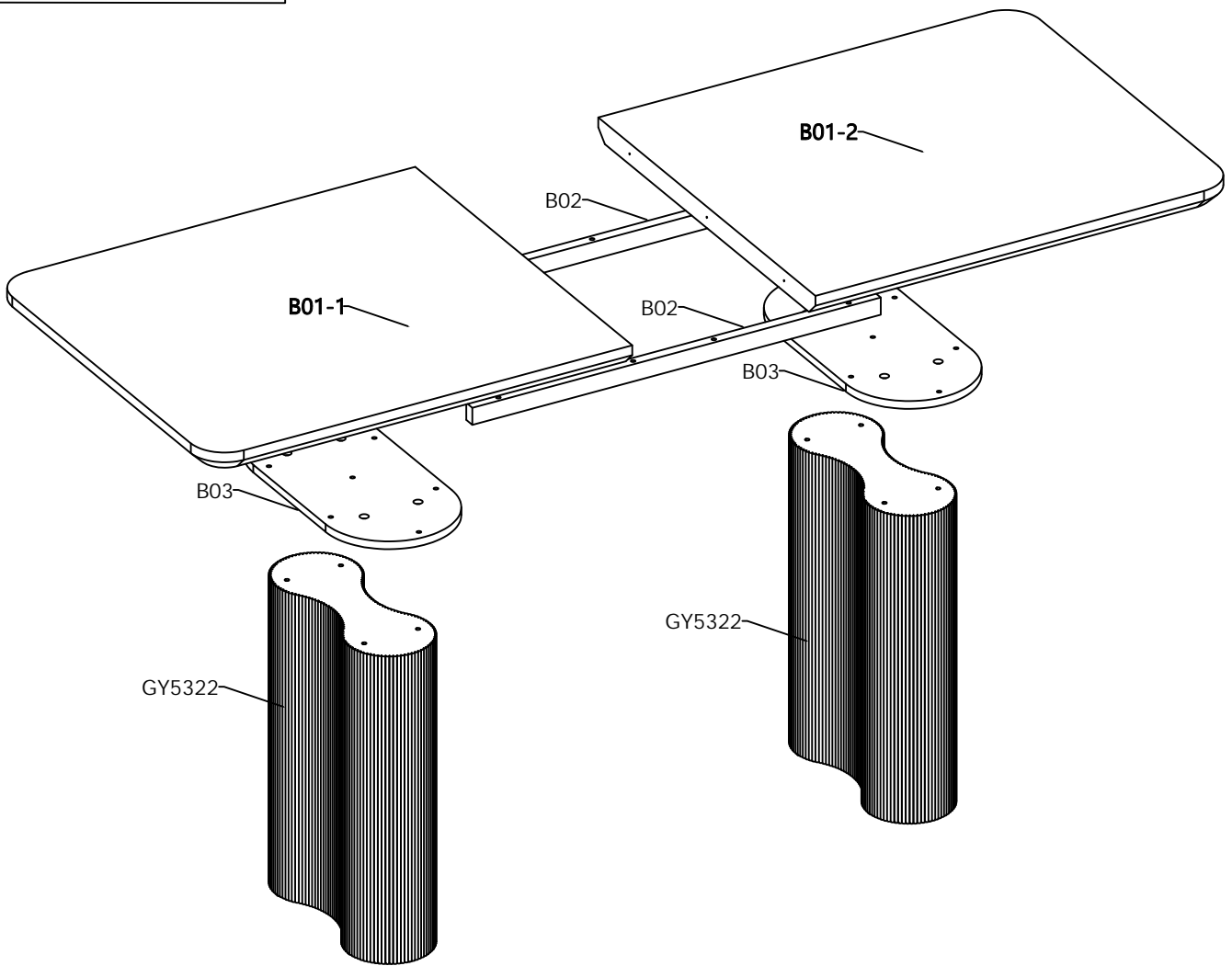



# WE'RE HERE TO HELP

how to get in touch with us



866-504-7728



support@guyii.com