

PRODUCT CARE HANDBOOK

a guide to protecting your product

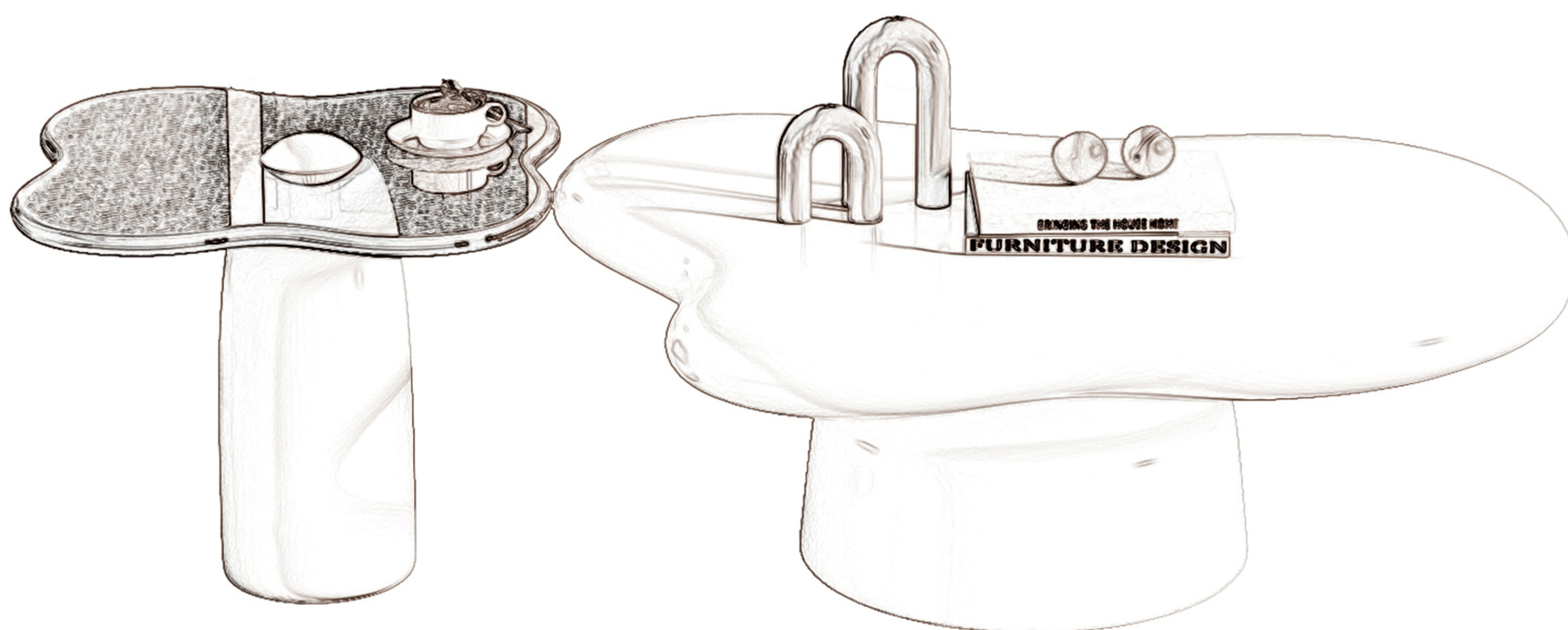

I'm made from 100%
recycled paper



866-504-7728



support@guyii.com

www.guyii.com

Coated with matte finish

Synthesize with varnish as main and matte agent as auxiliary

The board is coated with polymer emulsion

As a base coat polished for 6 times

Polishing undercoat

Polish with waterproof sandpaper and abrasive cloth

Medium density fiberboard

Not easy to deform or crack

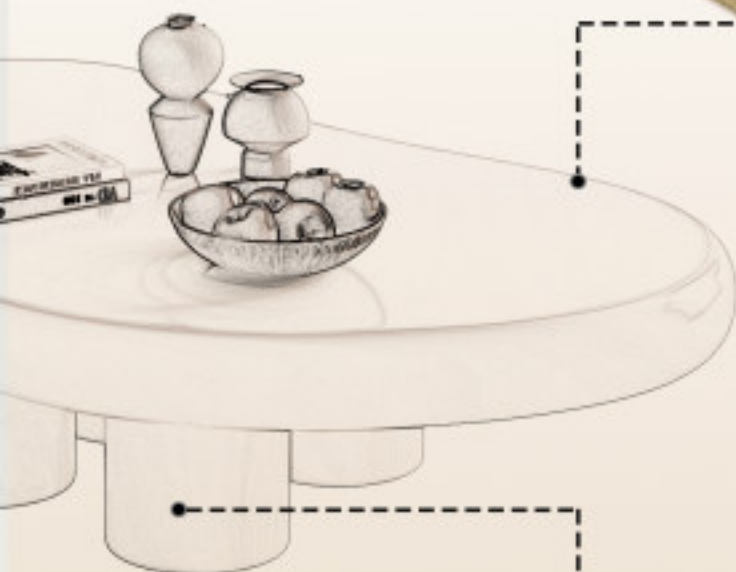

Coated with matte finish

Synthesize with varnish as main and matte agent as auxiliary

Polyvinyl chloride base

waterproof and damp-proof

Thank you for purchasing this product. Please read these instructions fully before starting assembly, then follow the simple step by step guide.

TOP TIPS BEFORE YOU START!

1. Please check that all parts & hardware are present before you start the assembly of your furniture. Do not destroy any of the packaging until you are certain that you have all the necessary parts for assembly.
2. For ease and speed of assembly, we recommend that before you commence each step of the assembly, please identify all the parts required for that step.
3. We recommend that where possible, all items are assembled near to the area in which they will be placed in use, to avoid moving the product unnecessarily once assembled.
4. For the protection of your furniture, particularly items of high gloss finish, we recommend that the product is placed on a protected surface during assembly to prevent any damage.
5. During assembly please take care not to over-tighten any fittings, as this may damage the product.
6. Keep children and animals away from the work area, small parts could cause choking if swallowed.

Tools Required For Assembly



DO NOT USE POWER TOOLS TO ASSEMBLE THIS PRODUCT. USE OF POWER TOOLS WILL INVALIDATE ANY CLAIM AND MAY DAMAGE THIS PRODUCT MAKING IT UNSAFE.

Rubber Hammer



Self-provided general tool diagram:

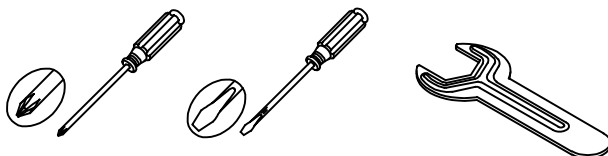

Tape Measure

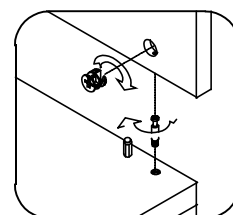
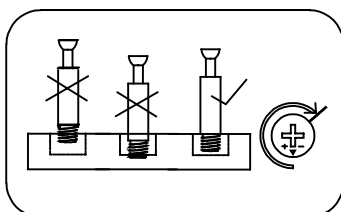

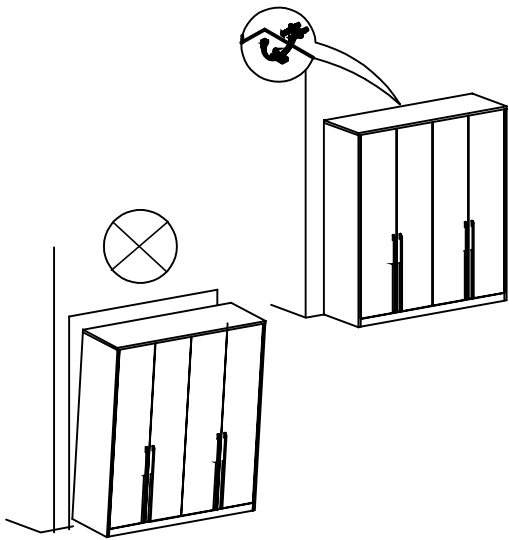



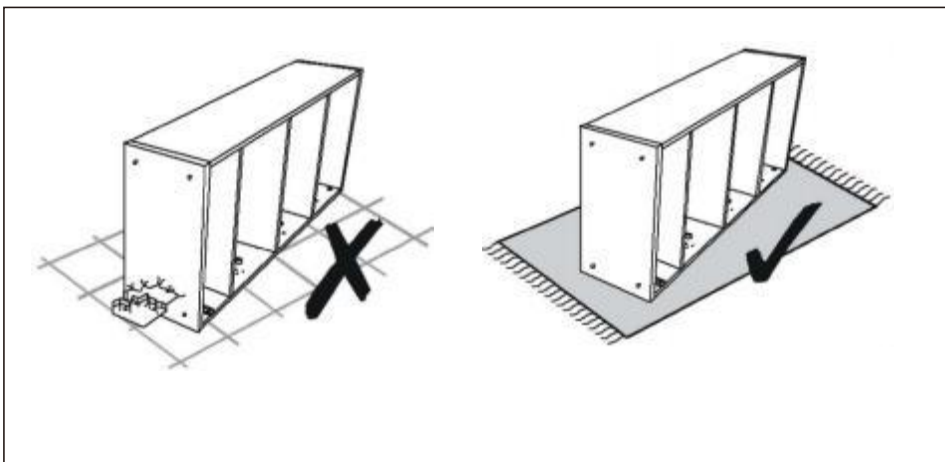
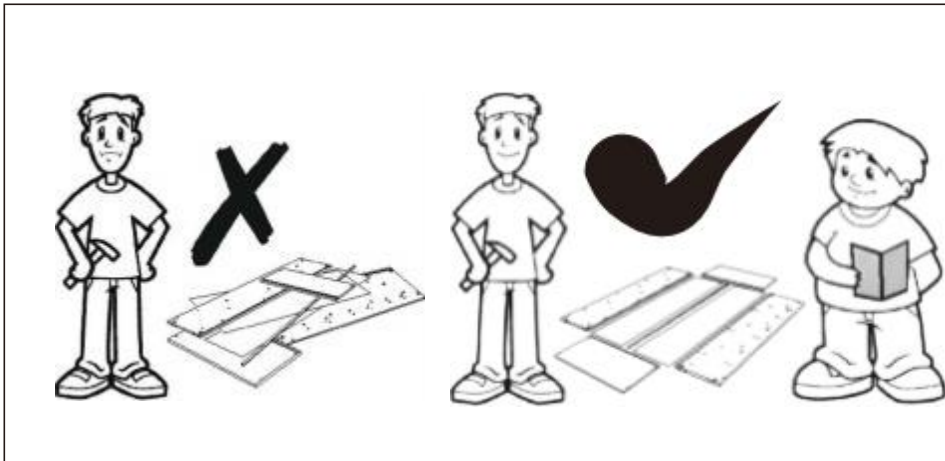

matters needing attention

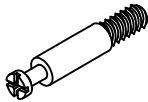
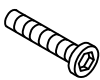

GY1683 Installation Hardware List

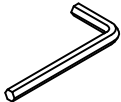
<p>H1201</p>  <p>Eccentric wheel Φ 14.5 * 11.5</p> <p style="text-align: right;">34PCS</p>	<p>H1101</p>  <p>Three in one pole Φ6*40</p> <p style="text-align: right;">34PCS</p>	<p>H1124</p>  <p>Pan screw M6 * 30</p> <p style="text-align: right;">12PCS</p>	<p>H2525</p>  <p>Felt mat</p> <p style="text-align: right;">8PCS</p>
<p>HA0095</p>  <p>Double headed screw M8 * 405</p> <p style="text-align: right;">2PCS</p>	<p>H1511</p>  <p>asket M8 * 18</p> <p style="text-align: right;">2PCS</p>	<p>HA0098</p>  <p>Hexagonal locking nut</p> <p style="text-align: right;">2PCS</p>	<p>H5105</p>  <p>inner hexagon spanner</p> <p style="text-align: right;">1PC</p>

GY1683 (large) installation steps

Step1:
Install H1101 in advance on B05

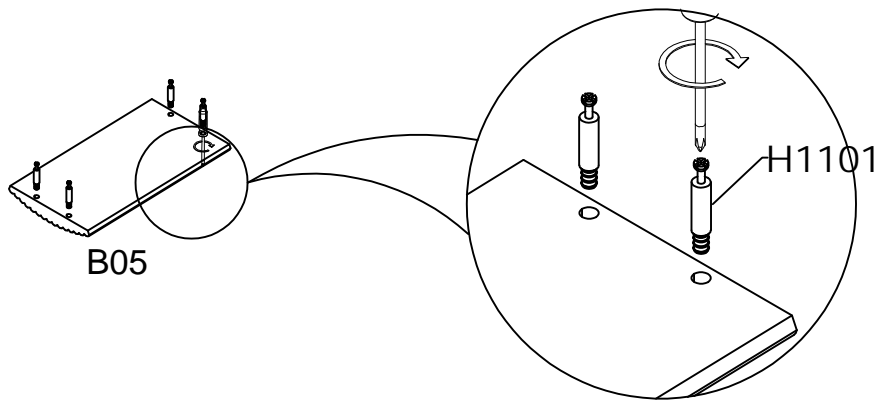

Step2:
Align the B05 with H1101 installed and insert it into the B04 hole

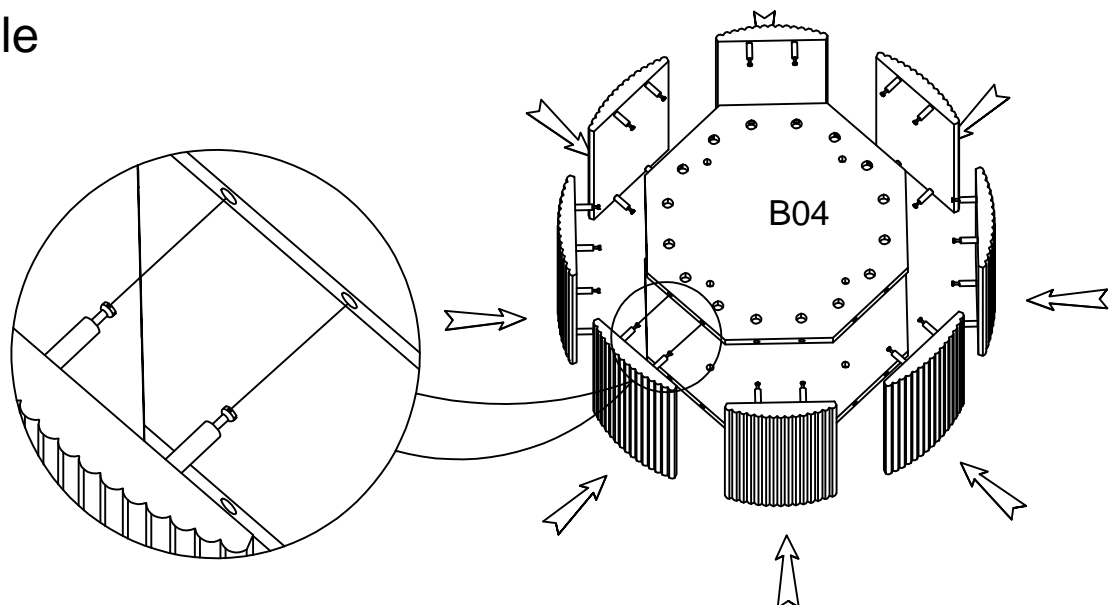

Step2:

After inserting B05 into B04

Lock with H1201

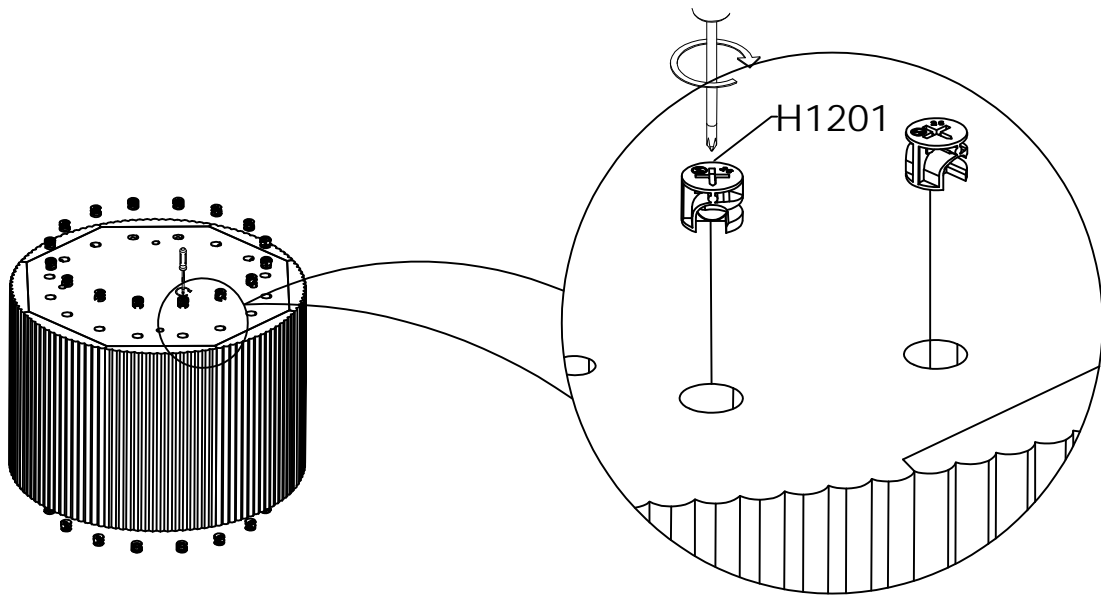

Step3:

Install B02 using H5105

and H1124

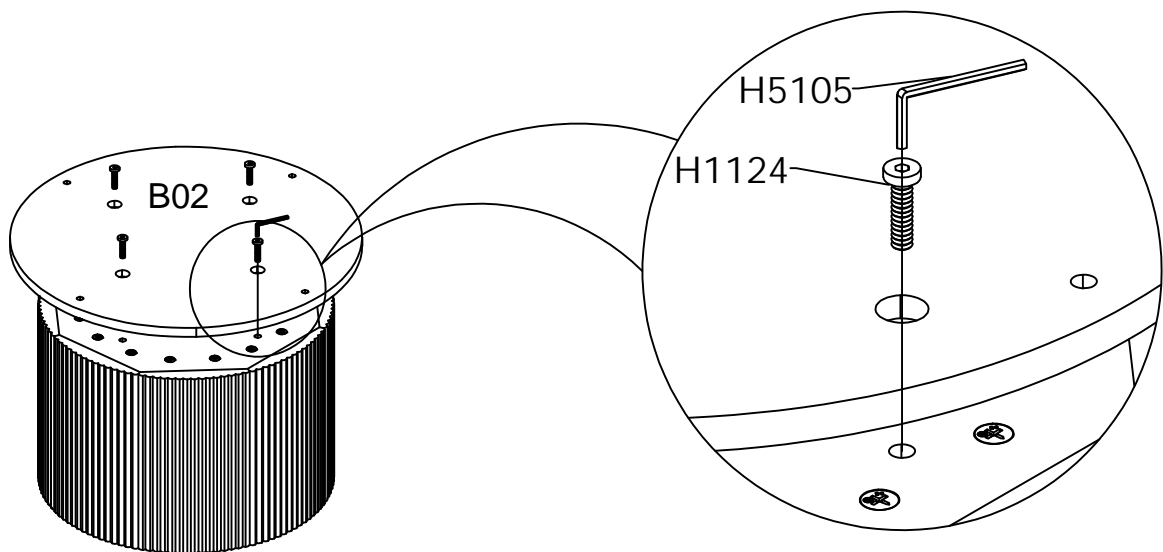

Step4:

Install B03 using H5105 and H1124

Paste H2525 at the bottom of B03

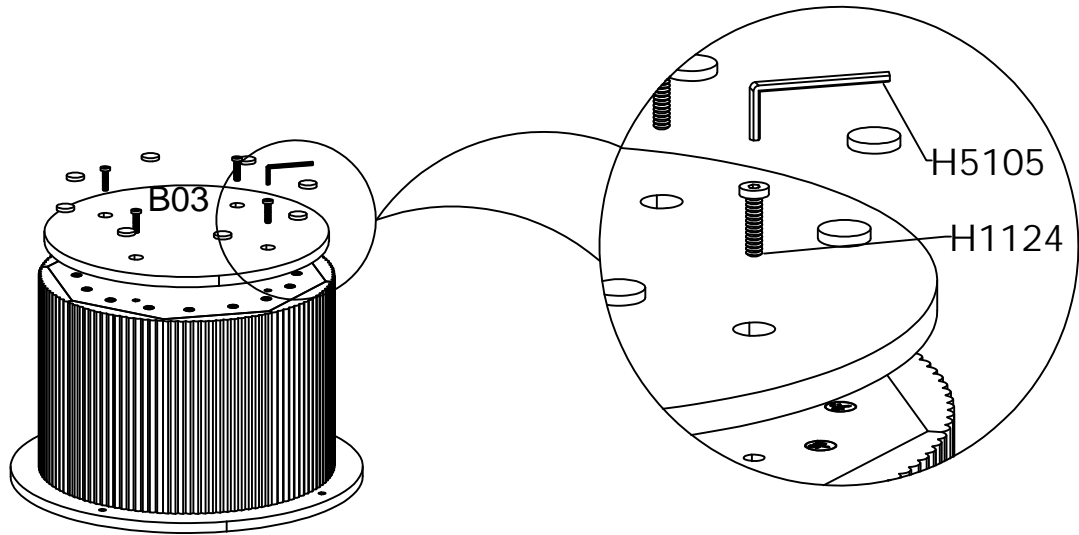

Step5:

Install B01 using H5105 and H1124

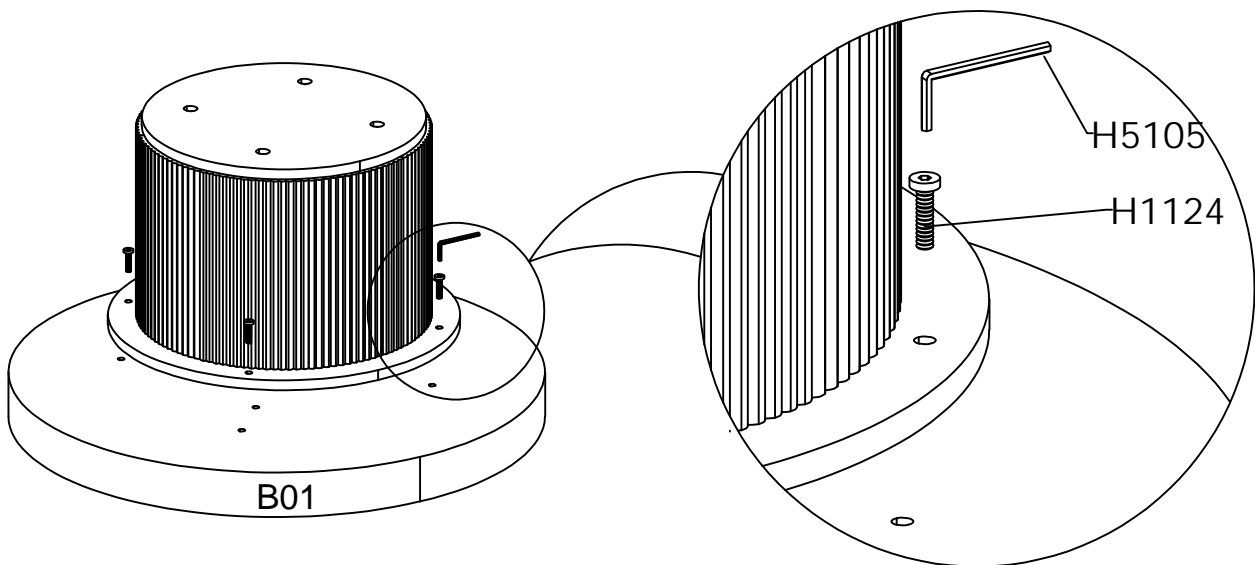

GY1683 (small) installation steps

Step1:

Install the lead screw onto B06

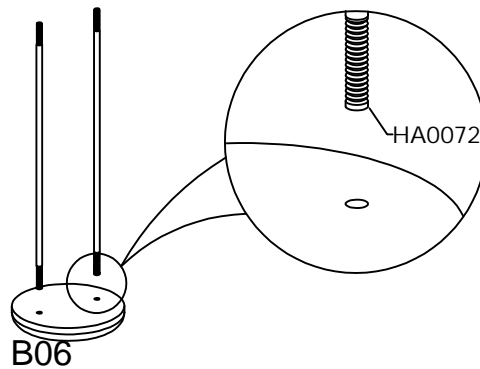

Step2:

Insert B07, B08, B09 into the screw rod in the order shown in the figure

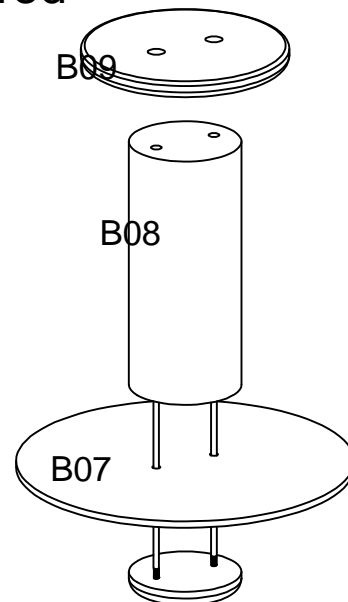

Step3:

Use H1511, HA0098, H5105 to lock B04

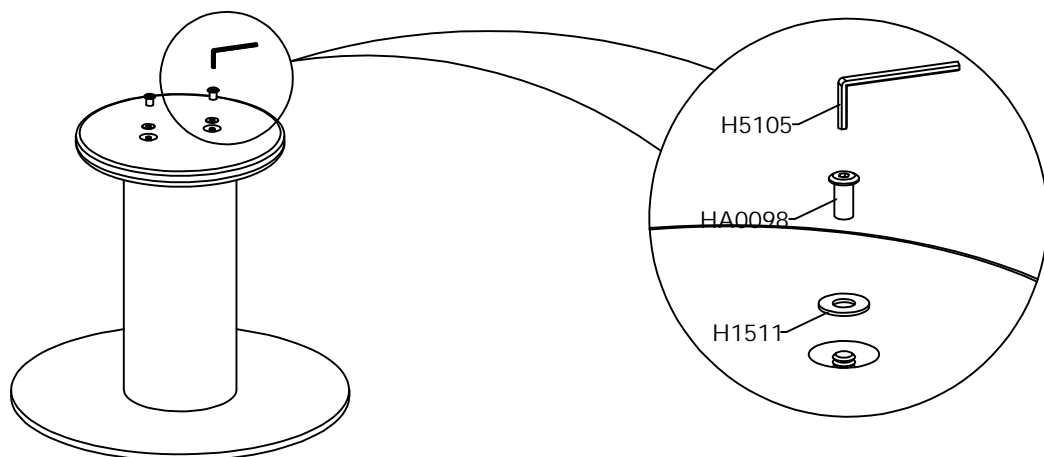

GY1683 (大) 板件清单

B01*1 Large panel
B02*1 Large Link Board
B03*1 floor
B04*2 Small Link Board
B05*8 Fence board
B06*1 Small coffee table top plate
B07*1 Tempered glass
B08*1 mall coffee table pillar
B09*1 Small coffee table bottom plate

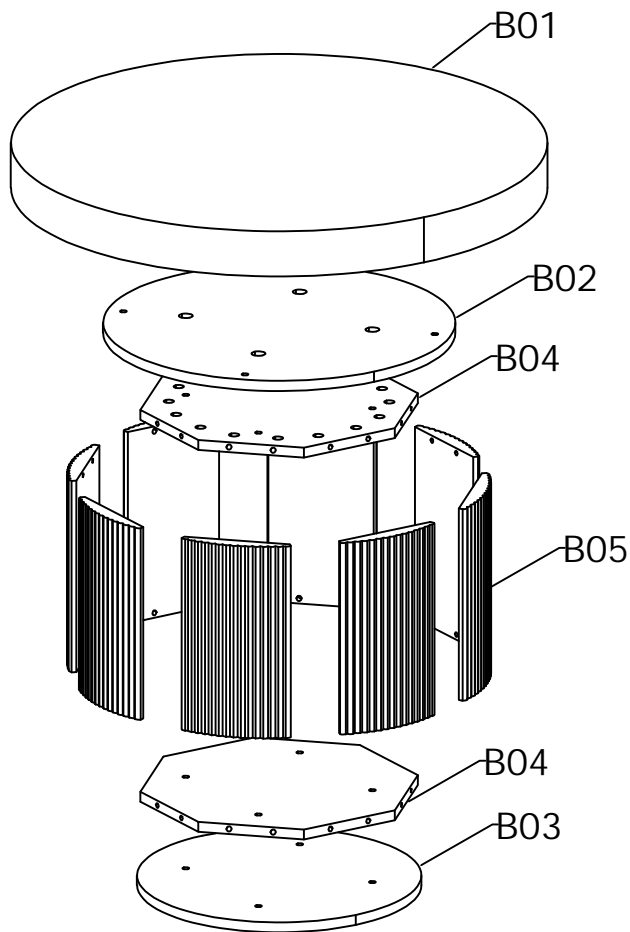
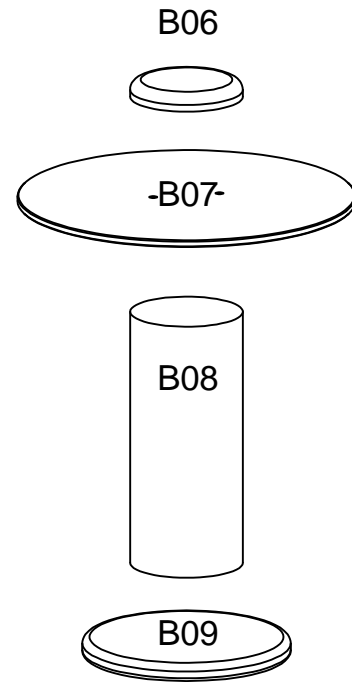

WE'RE HERE TO HELP

how to get in touch with us



866-504-7728



support@guyii.com
